

Notes and Standards docs

Notes and Standardization guides

- Labels and CAD Identifications
 - Device, Cable, and Panel Labeling scheme.
 - Badge Reader Install Notes
- Recommended Vendors List
- ARM and Friends Home Servers Project

Labels and CAD Identifications

Device, Cable, and Panel Labeling scheme.

This is constantly changing as I try to document and standardize what I do in my installations.

Hardware and Labels used:

Printer: Brady M710 Label Maker:



Labels:

Label Type	Label Size	Brady Part Numer [URL]	Count Per Roll	Estimate Price	Required Ribbon
Basic Sticker	1.0" x 1.0"	M7-19-423	250	\$43.50	
Metallic Label	1.0" x 2.0"	M7-20-435 ■	100	\$40.00	
Cable Wrap Sticker	1.5" x 1.0"	M7-31-427	250	\$68.00	R4300 - \$73.00

Printable Site Template Guide:

Editable Document: [NetworkIdentification.docx](#)

Network Label and Color Master Key

Map Color Identification [Devices]:

Color	Device	Note
Orange	Server-IDF-MDF	
Blue	Standard Network Port	Access Layer
Yellow	Camera Location	
Red	Door / Access Control Location	Door + Badge Reader
Purple	Remote Switch	POE Switches
Green	Wireless AP	

Patch Cable Identification [Devices]:

Color	Device	Note
Orange	Service Cable	Trunk Servers Uplinks
Blue	Standard Network User	Access Layer
Yellow	Camera Network	Access Layer
Red	Door / Access Control Network	Access or Trunk [Unifi = Trunk]
Orange	Remote Switch / Wireless AP	Trunk Servers Uplinks

Cable Labeling Guide:

If using Patch Panel:	If Direct to Switch	Expansion:
SITE-LOCATION-PANEL.NUMBER	SITE-LOCATION-SWITCH.NUMBER	Adding letters to the number

Examples:

Market Hall, Cable from ground floor IT Room [Chad's office] 2 nd patch bay to first floor camera:	MHF-IDF.1.1 PNL01.01
Market Hall, Cable from basement [MDF] to first floor camera, #12:	MHF-MDF.0.1 PNL01.12
Market Hall, Cable from understairs switch to 3 rd floor door #20	MHF-IDF.1.2 SW02.20
Market Hall, Cable from understairs switch to 3 rd floor door #20, newly added	MHF-IDF.1.2 PNL02.20a

Panels / Doors Labels:

All panels are counted clockwise from either MPOE or Main Entry.

Start at the Main Doorway and count clockwise around the Facility.

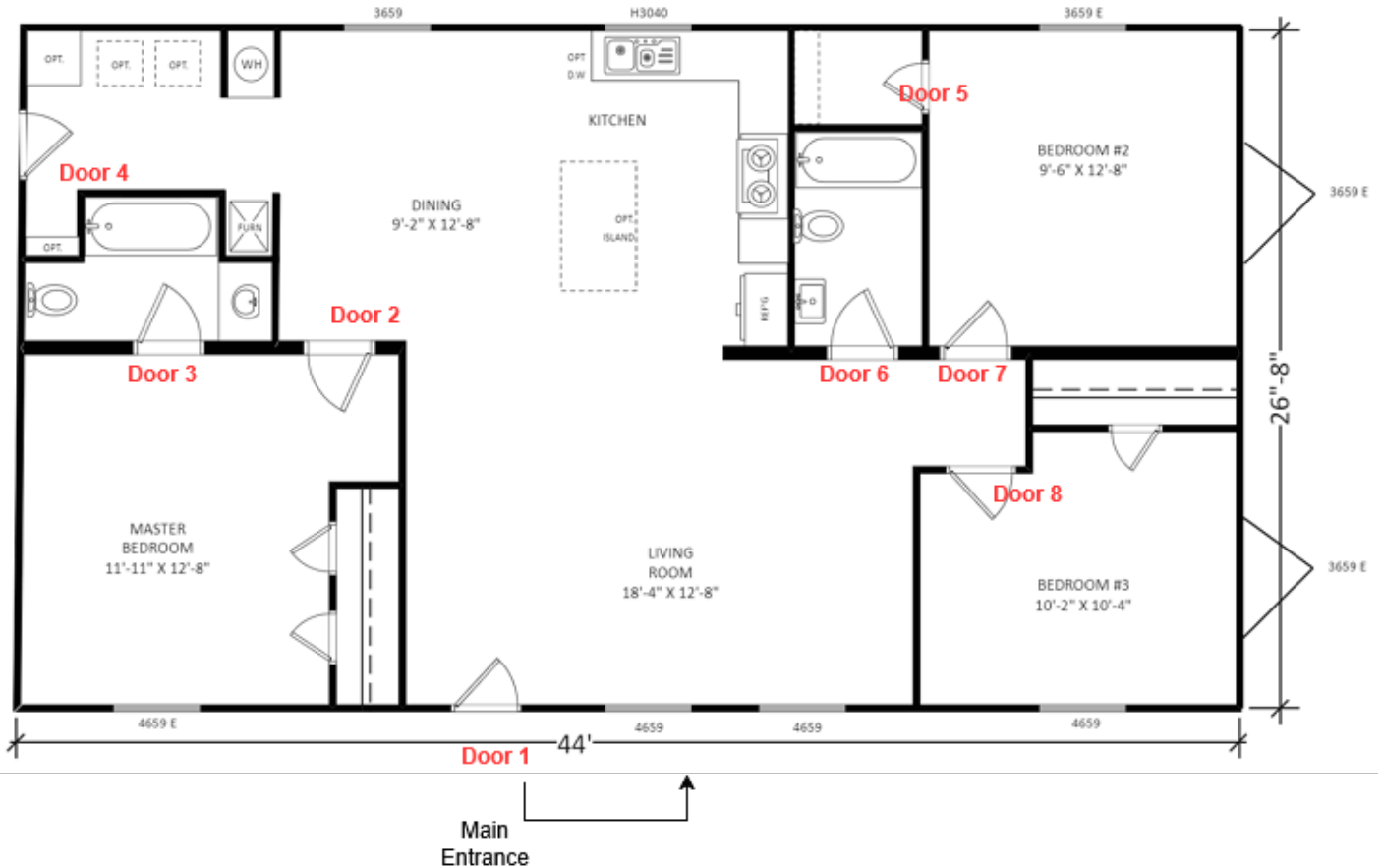

Location/Type	First	Example	Expansion
Main Point of Entry	(Site)-MPOE.(Floor).(door)	SASC-MPO.1.6	N/A - Only 1 MPOE per side
Intermediate Distribution Frame	(Site)-IDF.(Floor).(Door)	SASC-IDF.1.1	IDF-1-1a, IDF-1-1b
Media Cabinets/Panels	(Site)-PNL.(Floor).(Panel Number)	SASC-PNL.1.1, SASC-PNL.2.1	
Facility Doors:	(Site)-FL-DR##	SASC-01-DR01	

Notes:

MPOE - This is where the internet comes into the building. In residential buildings, it is commonly seen as a utility hidden under stairs or in basements. In large commercial buildings, it's widely known that risers [cables that link IDFs in other floors or wings] are used.

IDF - This is where your switching or server equipment is located to support each floor. This commonly hosts switches that connect back to the MPOE

Cable Labels:

606-B Notes:

Near end = AG09-35:01/AJ06-35:01

Far end = AJ06-35:01/AG09-35:01

If standing at rack location AG09, reading this near-end cable identifier will describe both the near-end and far-end locations.

AG09 = Rack or cabinet at grid location AG09 within the data center

-35 = Patch panel located 35 rack units from the bottom in rack AG09

:01 = Port 01 in patch panel located 35 rack units from the bottom of rack AG09

/ = Separator for near-end/far-end location description

AJ06 = Rack or cabinet at grid location AJ06 within the data center

-35 = Patch panel located 35 rack units from the bottom in rack AJ06

:01 = Port 01 in patch panel located 35 rack units from the bottom of the rack in AJ06

Examples	First	Example	Expansion
SASC Patch Bay to Environment	(Panel Number).(Port Number on Panel)	P6.12	P6.12a P6.12b [only applies to split cables]
SASC to Device	(Panel Number).(Port Number on Panel)	P6.12	P6.12a P6.12b [only applies to split cables]
Wilson-MHF	(site)-(IDF#)-(Panel Number).Port Number	MHF-IDF2.1-P1.1	N/A

Device Labels:

Controllers: Physical hardware in Panels, Walls or mounted to walls

Location/Type	First	Example	Expansion
Door Access Hub	(site)-CTL.(floor)-(door number)	SASC-CTL.1.05	SASC-CTL.1.05a
Door Intercom	(Access Hub)-IntCom	SASC-CTL.1.05-IntCom	IntCom
Door Badge Reader	(Access Hub)-Reader	SASC-CTL.1.05-Reader	

Network Devices:

Location/Type	First	Example	Expansion
Firewall/Router	(site)-FW##	925-FW01	925-FW02
Switches	(site)-SW##	925-SW01	925-SW02
Cameras	(location)-(object-in-camera)	INTERNAL-CashReg	INTERNAL-CashReg02

Notes:

Cameras have special naming schemes. We define them as internal or external to quickly identify access. Tenants and Employees typically can access external cameras, but internal camera access is heavily policed. A camera overlooking a driveway would be called "EXTERNAL-Driveway-North"

Patch Bay printed label templates:

[PatchBaySize_12portLevitonKeystone.docx](#)

[PatchBaySize_12portSurfacemount.docx](#)

[PatchBaySize_24portKeystone.docx](#)

[PatchBaySize_48port.docx](#)

[PatchBaySize_24port.docx](#)

Wire In between Devices:

2x Layer labels. Order of spanning tree. Top of label = First location. The bottom of the Label = end of the cable.

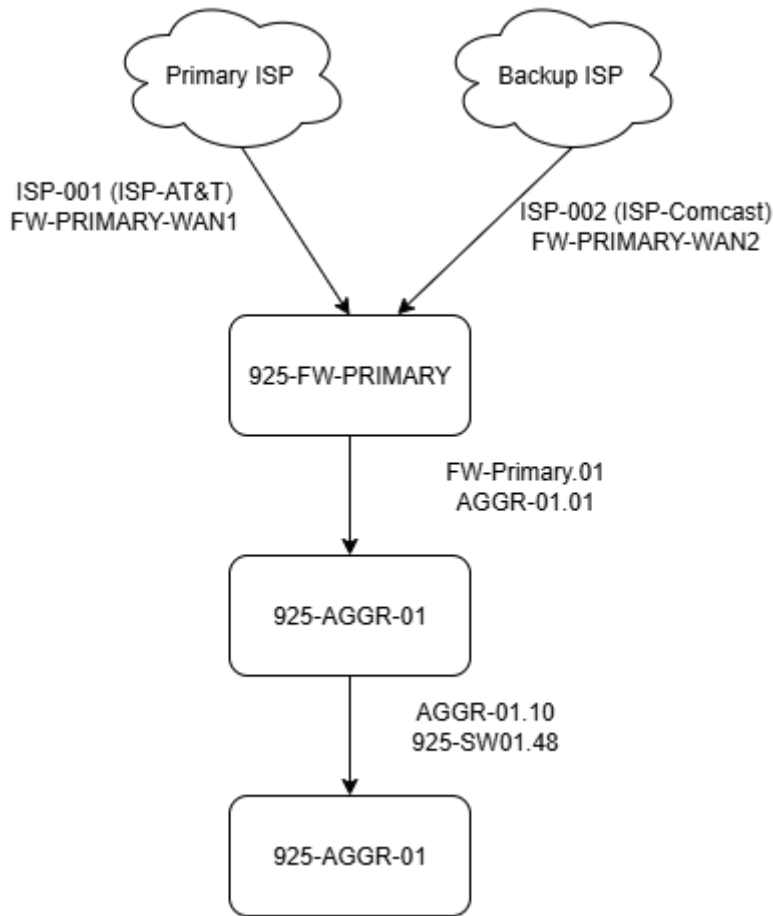

Device	Fire	Example	Expansion/Options
Device	Top: Where it terminates Bottom: What it terminates		
ISP to Firewall/Router	(site)-ISP.## [Number or name] FW-Primary-PORT	MHF-ISP.001 FW-Primary-WAN1	ISP-AT&T FW-Secondary-WAN2
Router to Distribution Switch	FW/ROUT.Port AGGR-##.PORT	FW-Primary.03 AGGR-01.01	FW-Secondary.03 AGGR-02.01
Router/Agg to L3/2 Switch IN MPOE	AGG-##.Port SW##.Port	AGGR-01.10 SW01.49	AGGR-02.12-BONDa AGGR-02.13-BONDb
Patch Cables between IDF/MPOE and the environment	(thing)-(floor)-(number) Service*-### *NET *TEL *COM	MHF-IDF.1.2 NET-001 *TEL-001	IDF-1-2 NET-001a
Riser Cables [between MPOE, IDF, Panels]	(site)- (thing).(floor).(number) (site)- (thing).(floor).(number)	MHF-IDF.1.001 SASC-PNL.2.001	IDF-1-1.001a, IDF-1-1.001b PNL-1-2.002a

Badge Readers	(site)-CTL.(floor).(number)-Reader	SASC-CTL.1.05-Reader	
Camera Cable	(thing)-(floor)-(number) CAM-###	SASC-CAM-1.05	
Access-Hub (not in panel)	(site)-CTL.(floor)-(door number)	SASC-CTL.1.1A	SASC-CTL.1.1B
Reader-Flex (no Hub)	(site)-CTL.(floor)-(door number)	SASC-CTL.1.1A	SASC-CTL.1.1B

Badge Reader Install Notes

Badge Reader Heights:

Note: Assume all measurements are to the "Center point" of object

Location - Customer	Interior Heights	Exterior Heights	Distance in from the doorjam	Special Notes	Paint/Color used
SASC	46" from Ground to Badge reader	47" from ground to center of badge reader.	Exterior: 7.5" from door jam, handle side	+ or - 2", varies based on if a light switch is in proximity of badge reader: Adjust to match switch center line	External Boxes: BEHR Chiffon Cream MATTE
Wilson's				ADA Compliance is a must with Wilson Properties.	

ADA Compliance

Legal Expectations: No lower than 36" and no higher than 48"

DOJ CFR Part 36 Official Notes:

Height and Reach Requirements

ADA has certain height and reach requirements to allow access for customers in wheelchairs. As these height and reach limitations may cause the weather overhang on keypads to obstruct the vision of taller customers, PTI sells a housing for keypads that does not have a weather overhang. APEX keypads may also be flush-mounted in a wall to prevent this issue. Either of these items may be purchased from PTI.

1. Keypads should be mounted so that the top of the number touchpad is no more than 48" above the finished floor with no obstructions in locations where wheelchair access is available only from the front. See Figure 1.

2. Keypads should be mounted so that the top of the number touchpad is no more than 54" above the finished floor with no obstructions in locations where the wheelchair has sideways access. See Figure 2.
3. Keypads should not be mounted so as to protrude more than 4" from the wall. If mounted in a bollard or pylon, it may protrude up to 12". Multiplexers and other items mounted higher on the wall or ceiling must be 80" or higher above the finished floor. See Figure 3.
4. Falcon Base Units and computers should be placed on desks that meet ADA requirements between 28" - 34" tall with no more than 20" in reach depth for obstructed front access or 24" in reach depth for obstructed side reach access. See Figures 4 & 5. In Figure 4, if $X < 20"$ then $Y = 48"$. When $X = 20"$ to $25"$, then $Y = 44"$. X should always be $\leq 25"$.

5.

Visual CAD:

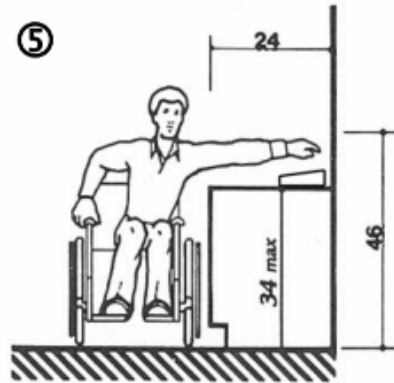
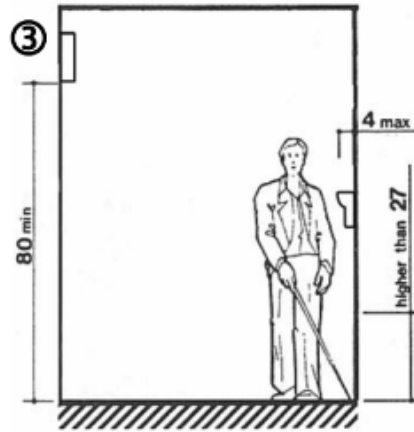
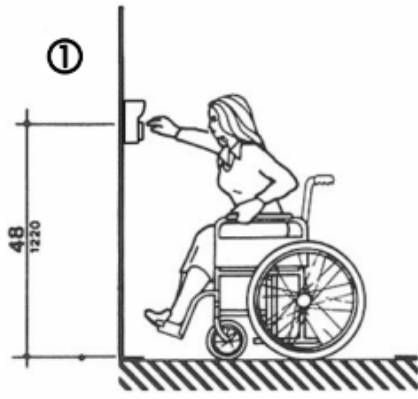

Recommended Vendors List

Facility Vendors

Service	Vendor Name [link to website]	Location	Notes/Feedback
Locksmith	<u>Parker Security & Locksmith</u> Contact:	Fremont, CA. Serving the greater East Bay	<p>They're great! Constantly doing their best to make sure we're getting the best price for our needs. They have a walk-in store in Fremont and will do rekeyings on the spot.</p> <p>As someone who "likes to do it themselves," they have been great with supplies and parts for projects, or helping me to install select components on doors while I do low-voltage/wiring.</p>

IT and System Administration Vendors

Service	Vendor Name [link to website]	Location	Notes/Feedback
---------	-------------------------------	----------	----------------

<p>Printers</p>	<p><u>Cortron Systems Inc.</u></p> <p>Contact: office@cortronsystems.com</p> <p>Contact: Devon@cortronsystems.com</p>	<p>San Jose, CA serves the greater Bay Area</p>	<p>We lease 15 Printers, including a very high-end Plotter for a 50+ inch prints. They offer a service that runs on Windows or Linux, though they recommend Windows, which monitors and reports the status of your printers back to them.</p> <p>I have 15 years of career in the IT space, and a Printer can be a real pain in the ass, especially at scale. Cortron is the best I've ever had the opportunity to work with. They're professional, knowledgeable about their technology, and excel in service and support. I've worked with them without issues on various complicated projects.</p> <p>We've upgraded printers in the office, and they have cloned configurations from the old to the new printer without issues, so our end users don't see any change in their process or have to "re-add" devices."</p>
-----------------	--	---	--

ARM and Friends Home Servers Project

Reason:

I wanted to build a DVD-ingest tool for Plex to let me and others rip DVDs to our Plex server. I have a stack of 8 small Dell mini desktops that are headed to e-waste. Instead of sending them off, I've taken them and am upgrading them here and there to be remote nodes at friends' houses for adding content to Plex, for hosting Home Assistant, and for running SteamOS as a home media center.

Warning

Expected Outcome:

Each unit will get:

Proxmox 9.2 installed

Custom network configurations for VPNing back to Plex Server

1x LXC Container running ARM [Vlan 10, Disk tray routed to LXC]

1x LXC Container running Home Assistant [Vlan 1, 1x USB port routed]

1x VM running SteamOS [Vlan 1, Graphic card routed, 2x USB port routed]

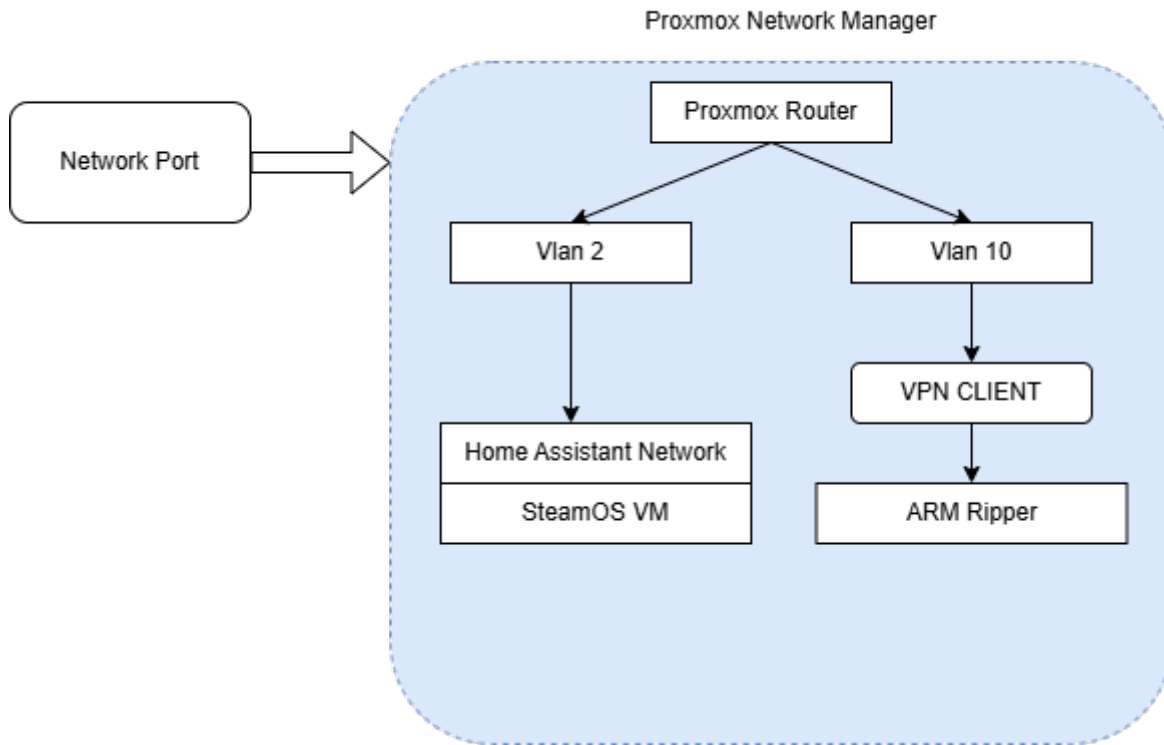

Research:

Knowledge/Learnings/Links/Notes

Use me to hide long guides

Steps Taken | Work done:

1. Step
2. by
3. step
4. process